

Panasonic

Stereo Radio Cassette Recorder

RX-FT530

Operating Instructions

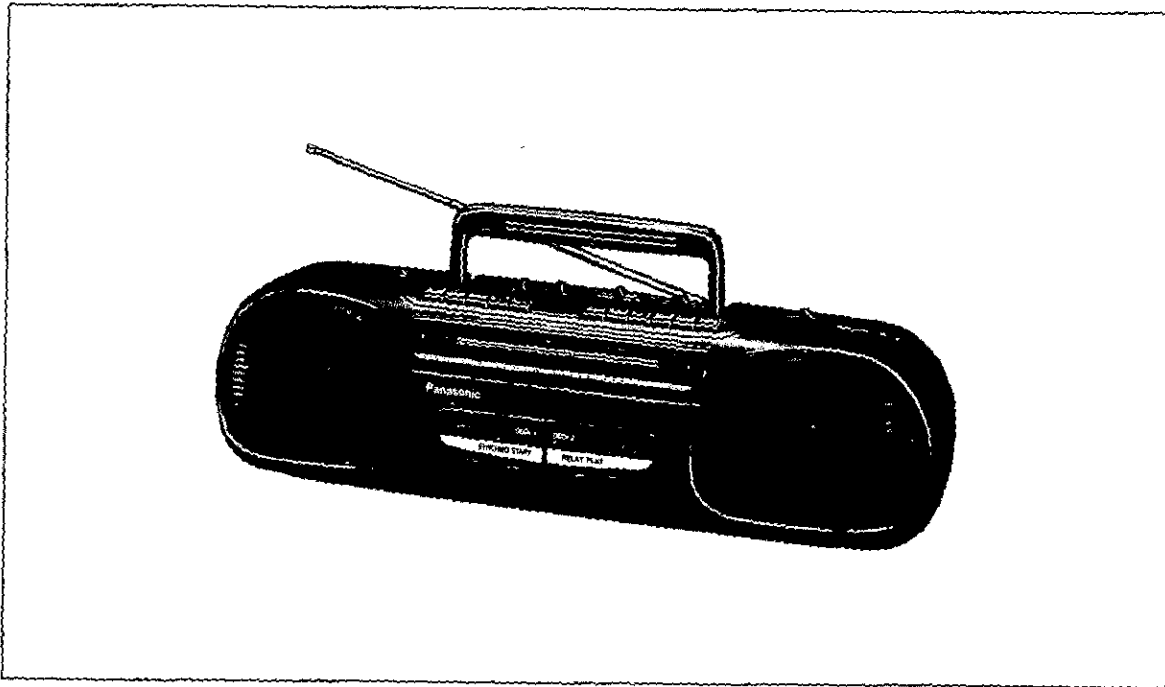

Table of Contents

Precautions	2	Listening to Radio Broadcasts	8
Supplied Accessory	4	Making a Recording	9
Power Sources	4	Care & Use	11
Location of Controls	5	Product Service	Back Cover
Listening to Tapes	6	Technical Specifications	Back Cover

Before connecting, operating or adjusting this product,
please read these instructions completely.

P PC

RQT2300-P

Placement

1. **Ventilation** -- The unit should be situated so that its location or position does not interfere with its proper ventilation. Allow 10 cm (4") clearance from the rear of the unit.
2. **Foreign Material** -- Care should be taken so that objects do not fall into and liquids are not spilled into the unit. Do not subject this unit to excessive smoke, dust, mechanical vibration, or shock.
3. **Magnetism** -- The unit should be situated away from equipment or devices that generate strong magnetism.
4. **Stacking** -- Do not place heavy objects, other than system components, on top of the unit.
5. **Surface** -- Place the unit on a flat, level surface.
6. **Carts and Stands** -- The unit should be used only with a cart or stand that is recommended by the manufacturer. The unit and cart combination should be moved with care. Quick stops, excessive force, and uneven surfaces may cause the unit and cart combination to overturn.
7. **Wall or Ceiling Mounting** -- The unit should not be mounted to a wall or ceiling, unless specified in this operating instructions.



Maintenance

Clean the cabinet, panel and controls with a soft cloth lightly moistened with mild detergent solution. Do not use any type of abrasive pad, scouring powder or solvent such as alcohol or benzene.

Service

1. **Damage Requiring Service** -- The unit should be serviced by qualified service personnel when:
 - (a) The AC power supply cord or the plug has been damaged; or
 - (b) Objects have fallen or liquid has been spilled into the unit; or
 - (c) The unit has been exposed to rain; or
 - (d) The unit does not appear to operate normally or exhibits a marked change in performance; or
 - (e) The unit has been dropped, or the enclosure damaged.
2. **Service** -- The user should not attempt to service the unit beyond that described in the operating instructions. All other servicing should be referred to qualified service personnel.

Listening caution

Selecting fine audio equipment such as the unit you've just purchased is only the start of your musical enjoyment. Now it's time to consider how you can maximize the fun and excitement your equipment offers. This manufacturer and the Electronic Industries Association's Consumer Electronics Group want you to get the most out of your equipment by playing it at a safe level. One that lets the sound come through loud and clear without annoying blaring or distortion—and, most importantly, without affecting your sensitive hearing. Sound can be deceiving. Over time your hearing "comfort level" adapts to higher volumes of sound. So what sounds "normal" can actually be loud and harmful to your hearing. Guard against this by setting your equipment at a safe level BEFORE your hearing adapts.

To establish a safe level:

- Start your volume control at a low setting.
- Slowly increase the sound until you can hear it comfortably and clearly, and without distortion.

Once you have established a comfortable sound level:

- Set the dial and leave it there.

Taking a minute to do this now will help to prevent hearing damage or loss in the future. After all, we want you listening for a lifetime.

We Want You Listening For A Lifetime

Used wisely, your new sound equipment will provide a lifetime of fun and enjoyment. Since hearing damage from loud noise is often undetectable until it is too late, this manufacturer and the Electronic Industries Association's Consumer Electronics Group recommend you avoid prolonged exposure to excessive noise. This list of sound levels* is included for your protection.

*The level used here is different from that displayed on the system's display.

Decibel

Level	Example
30	Quiet library, soft whispers
40	Living room, refrigerator, bedroom away from traffic
50	Light traffic, normal conversation, quiet office
60	Air conditioner at 20 feet, sewing machine
70	Vacuum cleaner, hair dryer, noisy restaurant
80	Average city traffic, garbage disposals, alarm clock at two feet.

THE FOLLOWING NOISES CAN BE DANGEROUS UNDER CONSTANT EXPOSURE

90	Subway, motorcycle, truck traffic, lawn mower
100	Garbage truck, chain saw, pneumatic drill
120	Rock band concert in front of speakers, thunderclap
140	Gunshot blast, jet plane
180	Rocket launching pad

Information courtesy of the Deafness Research Foundation.

Supplied Accessory

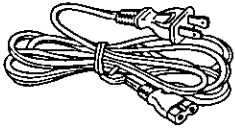

AC power cord 1 pc.
(SJA175-A)

Power Sources

To operate AC power

Connect the AC power cord (included).

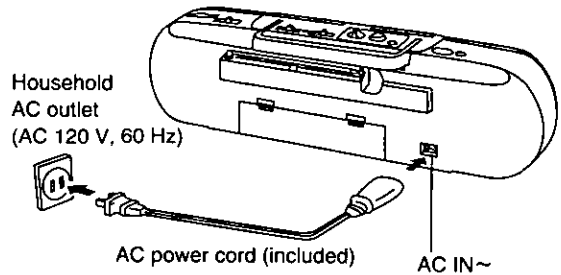

To operate on battery power

Unplug the AC power cord from the household AC outlet and the AC socket of the unit.

Insert six "D" size (R20/LR20 or equivalent, not included) batteries into the battery compartment in the designated numerical order.

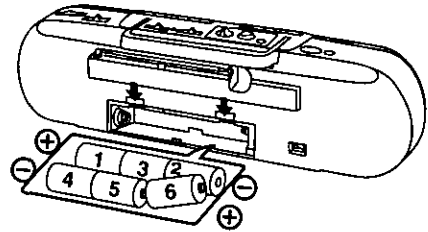

- Batteries installed with incorrect polarities may leak and damage this unit.
- Do not mix batteries (old and new) or types (carbon and alkaline, etc.).
- If the set is not used for a long period of time or is used only from an AC power source, remove the batteries to prevent potential damage from possible battery leakage.
- If you cannot open the cassette compartment cover when running this unit on batteries, replace the batteries with new ones, or use AC power source, and then perform the operation once again.

Battery removal:

Insert your finger, and then push out the batteries.

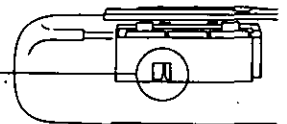

Battery life:

When the batteries get weak, the sound will become distorted and the volume will decrease.

Location of Controls

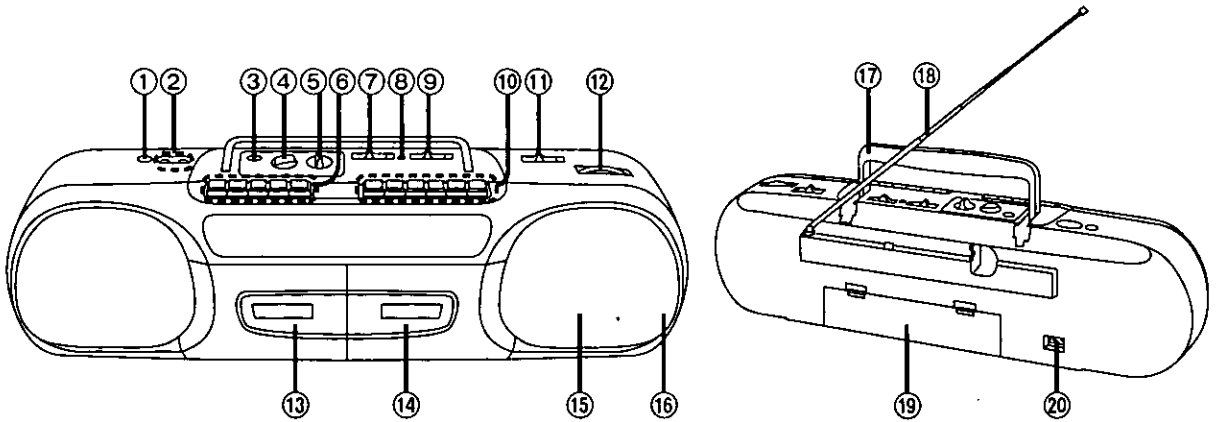

- ① Headphones jack (PHONES)
- ② CD/line input jacks (/LINE IN)
- ③ Built-in microphone (MIC)
- ④ Volume control (VOLUME)
- ⑤ Tone control (TONE)
- ⑥ Deck 1 (For playback)
 - Pause button (PAUSE)
 - Stop/eject button (STOP/EJECT)
 - Fast forward/cue button (/CUE)
 - Rewind/review button (/REV)
 - Playback button (PLAY)
- ⑦ Function selector (SELECTOR)
(TAPE/ , RADIO, /LINE)
- ⑧ FM stereo indicator (FM ST)
- ⑨ Editing mode selector/beat proof switch
(EDITING/B.P)
- ⑩ Deck 2 (For recording and playback)
 - Pause button (PAUSE)
 - Stop/eject button (STOP/EJECT)
 - Fast forward/cue button (/CUE)
 - Rewind/review button (/REV)
 - Playback button (PLAY)
 - Record button (RECORD)
- ⑪ Band selector (BAND)
- ⑫ Tuning control (TUNING)
- ⑬ Deck 1 cassette compartment
- ⑭ Deck 2 cassette compartment
- ⑮ Speakers (Woofer)
- ⑯ Speakers (Tweeter)
- ⑰ Handle
- ⑱ Telescopic antenna
- ⑲ Battery compartment
- ⑳ AC socket (AC IN~)

Connections

How to connect portable CD player

When listening or recording CD, set SELECTOR to /LINE.

How to use headphones (not included)

Reduce the volume level. Connect the headphones to the headphones jack.

- Avoid listening for prolonged periods of time to prevent hearing damage.
- Speakers are automatically cut off when the headphones are connected.

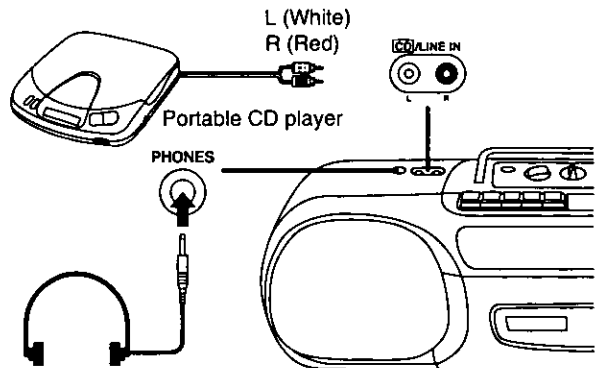



Listening to Tapes

You can use normal tapes only.

You can use either deck 1 or deck 2 for tape playback by following the same steps. (This page shows an example using deck 2.)

Single tape playback **A**

1  Set **SELECTOR** to **TAPE/OFF**.

2  Press **STOP/EJECT**, and then insert the tape.
 Insert the cassette with the exposed tape facing up.
Playback side

3  Press **PLAY** to start playback.

4  Adjust **VOLUME** and **TONE**.

To stop the playback:

Press **STOP/EJECT**.

To briefly interrupt the playback:

Press **PAUSE**.

To resume playback, press **PAUSE** again.

Full auto stop:

When the tape reaches the end, the tape will automatically stop.

To fast forward or rewind the tape **B**

Press **◀◀/CUE** or **▶▶/REV** while the tape is stopped.

The tape will start moving at high speed.

To stop the fast forward or rewind operation, press **STOP/EJECT**.

To cue or review the tape **B**

During playback, press and hold **◀◀/CUE** or **▶▶/REV**.

The recorded sound on the tape can be monitored at high speed.

When the button is released, normal playback will resume.

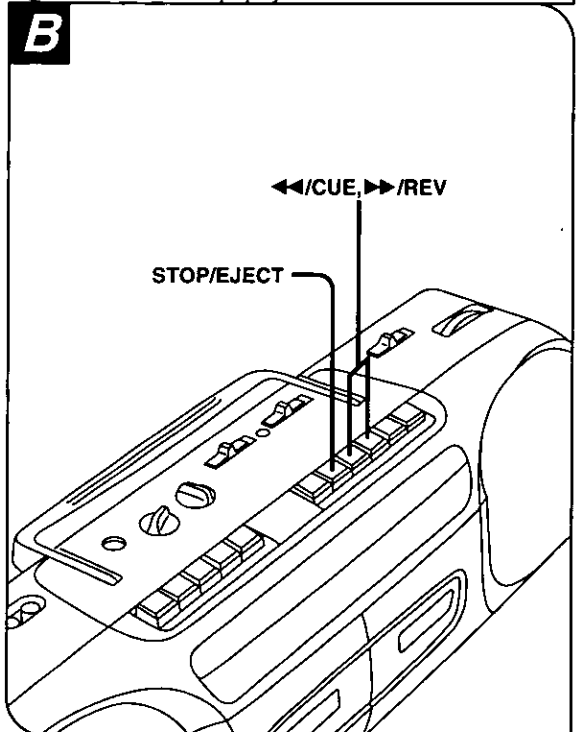
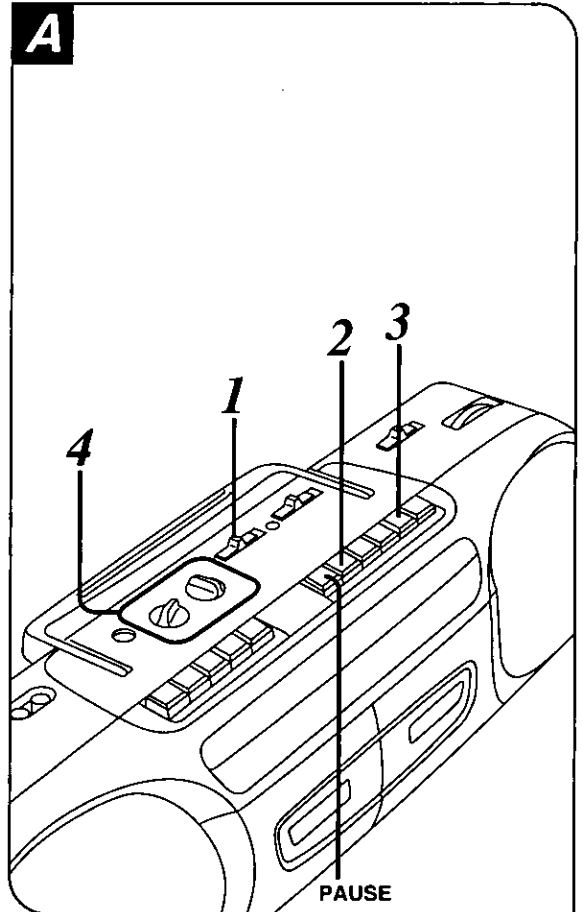



Automatic playback relay (deck 1 to deck 2)

When deck 1 playback has finished, deck 2 playback starts automatically.

1  Insert the playback tapes into deck 1 and deck 2.
Playback side

2  Press **PLAY** of deck 1.

3   Press **PAUSE** of deck 2, then press **PLAY**.

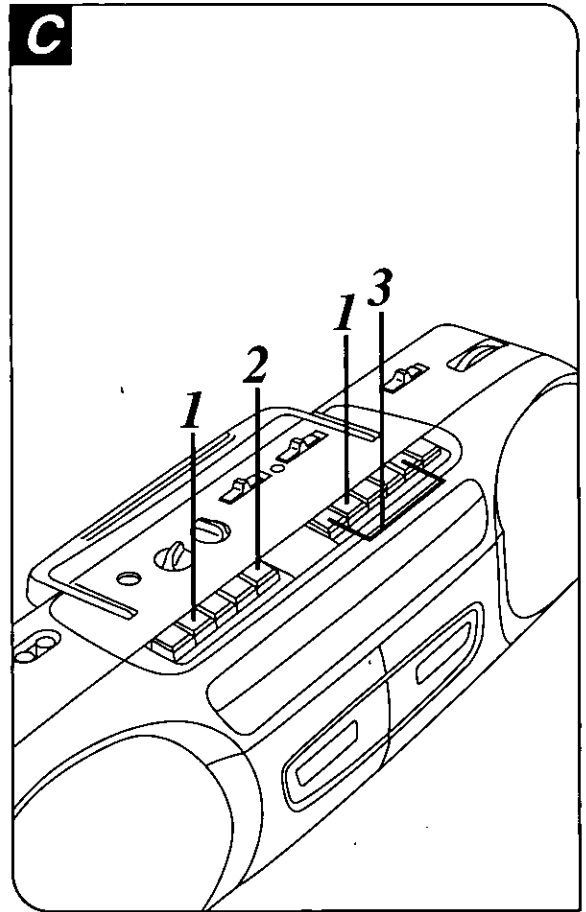

Listening to Radio Broadcasts

Refer to **A**.

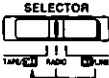
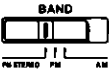
-  **1** Set **SELECTOR** to **RADIO**.
-  **2** Set **BAND** to the desired radio band.
FM STEREO: To receive FM stereo broadcasts
(If you have tuned into an FM stereo broadcast, the FM ST indicator will light.)
AM: To receive AM broadcasts

• If FM stereo reception is poor, set **BAND** to **FM**. This will reduce the noise and provide clear reception; however, the broadcast will not be heard in stereo.

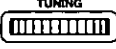
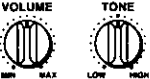
-  **3** Use **TUNING** to tune into a desired broadcast.
-  **4** Adjust **VOLUME** and **TONE**.

The radio can be turned off by setting **SELECTOR** to **TAPE/OFF**.

Adjust the antennas **B**

FM:
Pull out the telescopic antenna and adjust its length and angle for optimum reception.

AM:
Turn the unit in the direction which gives the best results.

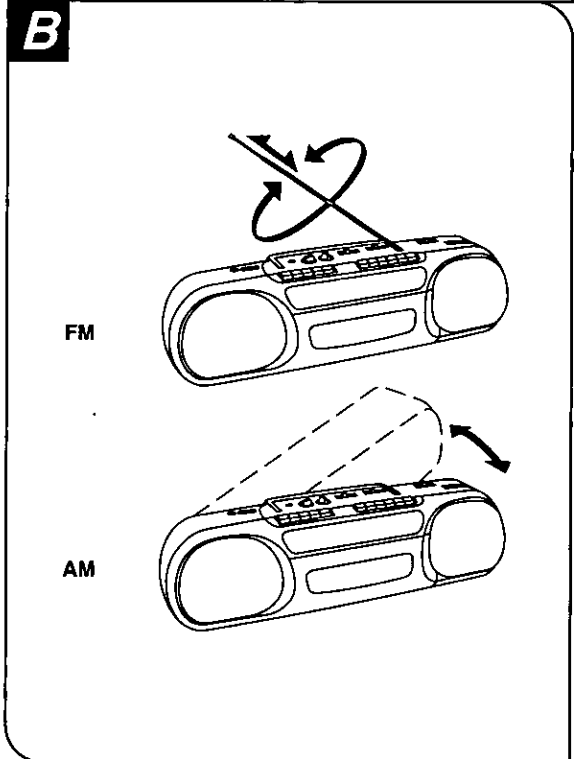
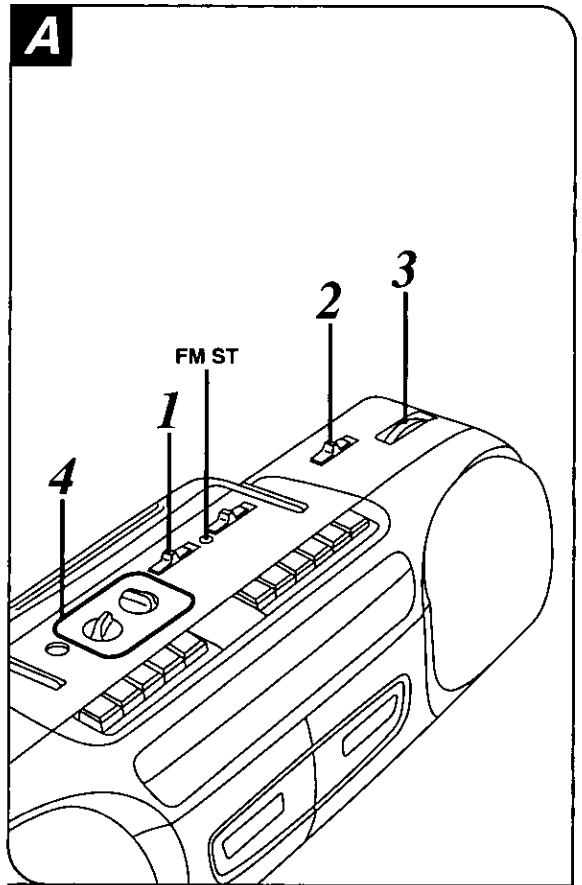

Making a Recording (deck 2 only)

You can use normal tapes only.
The recording level is automatically adjusted.

Recording from radio broadcasts **A**

1  Press **STOP/EJECT** of deck 2 to insert the tape.

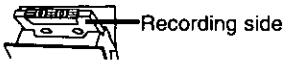

2 Tune into the desired broadcast. (Follow the procedure 1-4 of "Listening to Radio Broadcasts".)

3  Press **RECORD**.

When recording AM broadcasts:

B.P selector can reduce unwanted beat signals (whistle) which sometimes occur.

Set B.P to the position which gives best results.

To stop the recording:

Press **STOP/EJECT**.

To briefly interrupt recording:



Press **PAUSE**.

To resume recording, press **PAUSE** again.

Recording through the built-in microphone **B**

1  Set **SELECTOR** to **TAPE/OFF**.

2  Set **EDITING/B.P** to **MIC**.

3   Insert the tape into deck 2, and press **RECORD**.

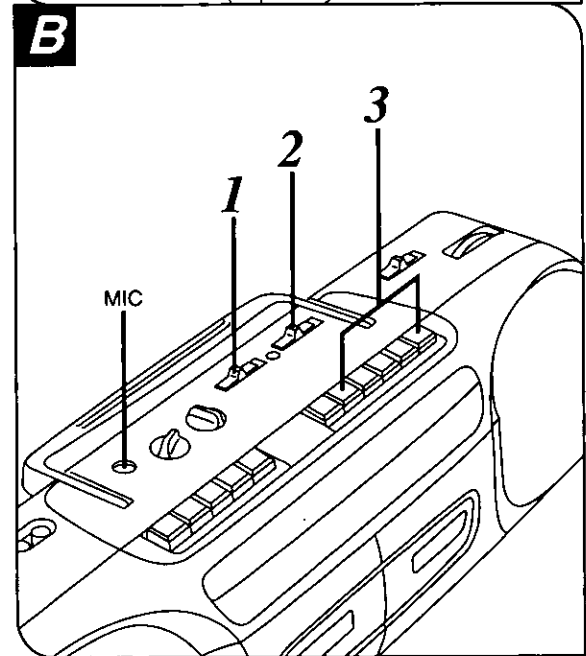
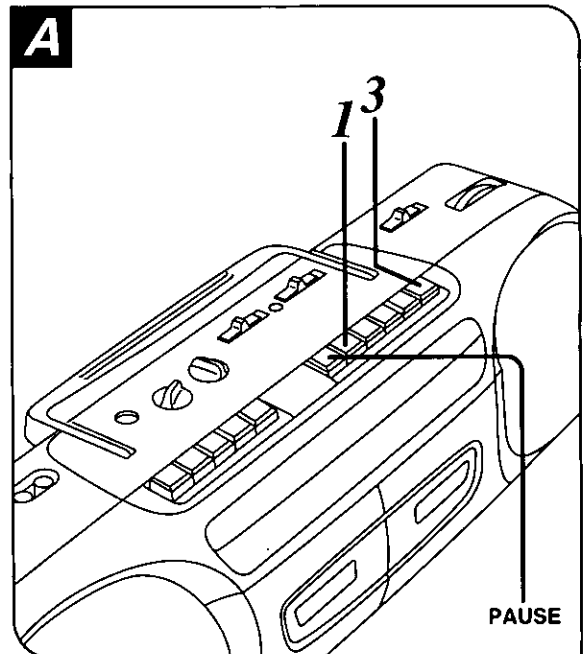

Pause button:

Before beginning a recording, first press and lock **PAUSE**.

Then press **RECORD**. (The tape will not move.)

When ready to record, press **PAUSE** to release it. This will start tape movement for immediate recording. Do not use **PAUSE** to stop the tape for a long period of time.

Monitoring:





The monitor system enables you to listen, through the speakers or headphones, to the sound as it is being recorded.

When recording from the built-in microphone the sound being recorded cannot be monitored.

Making a Recording (continued)

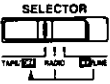
Recording from deck 1 to deck 2

When PAUSE and **RECORD** of deck 2 are pressed, tape recording starts by pressing the deck 1 playback button. (Synchro-start function)

-  Set **SELECTOR** to **TAPE/OFF**.
-  Insert the playback tape into deck 1 and the recording tape into deck 2.
-  Set **EDITING** to the desired position.
"NORMAL": Normal speed
"HIGH": High speed
-  Press **PAUSE** of deck 2, then press **RECORD**.
-  Press **PLAY** of deck 1.
Recording is started by means of the Synchro-start function.

To stop recording:

Press **STOP/EJECT** (deck 1 and deck 2).

- Do not change the tape speed during recording. The playback sound may flutter.
- Be sure to set **SELECTOR** to **TAPE/OFF** during recording. Do not change it to any other position.
- If the unit is brought near a TV set during recording, noise may be recorded due to the effects of the signals from the TV set. Maintain a distance of at least 1.5 meters between the unit and a TV set.

Erasure of tape

When recording, previously recorded signals on the tape will be erased automatically.
(Make no connections to the **CD** /LINE IN jacks.)

1. Set **SELECTOR** to **CD** /LINE.
2. Press **RECORD**.

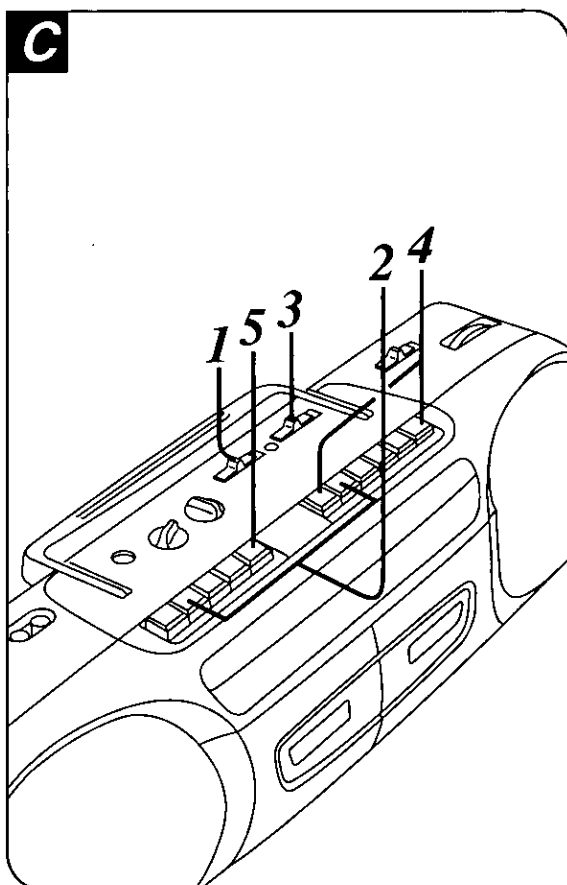

Recording from external equipment

- 1 Connect the output of the external equipment to **CD** /LINE IN jacks. (Refer to page 5.)
- 2 Set **SELECTOR** to **CD** /LINE, and insert the recording tape into deck 2.
- 3 Press **PAUSE** of deck 2, then press **RECORD**.
- 4 Start playing the external equipment (ex. portable CD player).
- 5 Release **PAUSE**.

Care & Use

Concerning cassette tapes

Selection of cassette tapes

You can use normal tapes only.

Cassette tapes exceeding 90 minutes:

These tapes are handy for their long playback and recording time but be careful about repeatedly stopping and starting, rewinding and fast forwarding these tapes in short intervals as they are thin, tend to stretch and may become entangled in the deck mechanism.

If the tape loosens, take up the slack

Tape slack may cause the tape to break.

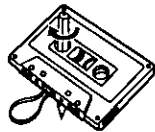

To prevent erasure of recorded sounds

Remove the erase-prevention tabs with a screwdriver or a similar object.

To re-record on a protected cassette, cover the slot with adhesive tape.

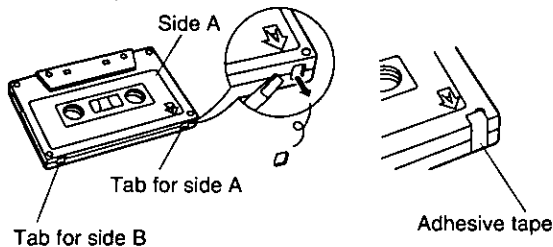

Improper tape storage:

You can damage tapes if you store them in the following places:

- In high temperature [35°C (95°F) or higher] or high humidity (80% or higher) areas
- In a strong magnetic field (near a speaker, on top of a TV, etc.)
This can erase a recording.
- Areas exposed to direct sunlight

Tape head care

To assure sound quality for recording and playback, be sure to clean the tape heads after approximately every 10 hours of use.

1 Open the cassette compartment cover by pressing **STOP/EJECT**.

2 (Deck 1)
Press **PLAY**.

(Deck 2)

While pushing erase prevention lever downward as shown, press **RECORD**.

3 Clean the head(s), pinch roller and the capstan with a cotton swab (or a soft, lint-free cloth) slightly moistened with isopropyl alcohol.

Do not use any solution other than alcohol for head cleaning.

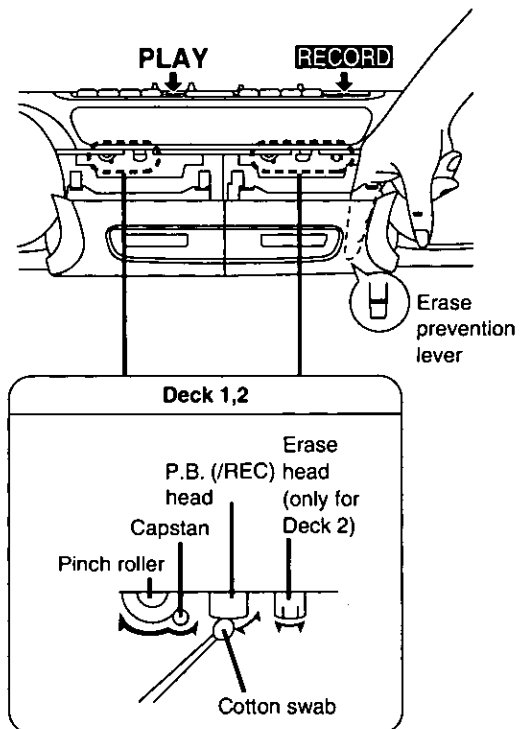

It is recommended that the head assembly be demagnetized if distortion or poor sound quality persists after cleaning the heads.

Demagnetize them using a demagnetizer available from an audio store.

Product Service

Do not attempt to remove the cover(s) or repair the unit yourself. Refer servicing to qualified personnel only.

Product information

For product service, product information or assistance with product operation, refer to the servicenter directory.

Technical Specifications

Radio

Frequency range: FM; 88–108 MHz
AM; 525–1705 kHz

Tape recorder

Track system: 4 track, 2 channel, stereo
Recording system: AC bias, magnet erase
Monitor system: Variable sound monitor
Frequency range: 70–12000 Hz (Normal)

General

Power requirement: AC; 120 V, 60 Hz
Power consumption: 15 W
Battery: 9 V
(six "D" size batteries)

Speakers: 2 Woofers; 10 cm (4")
2 Tweeters; 1.5 cm ($\frac{9}{16}$ ")

Jacks:
Input; CD/LINE IN; 398 mV/47 k Ω
Output; HEADPHONES; 32 Ω

Dimensions (W×H×D): 566×146×160 mm
(22 $\frac{5}{16}$ "×5 $\frac{3}{4}$ "×6 $\frac{5}{16}$ ")

Weight: 2.8 kg without batteries
(6 lb. 3 oz.)

Note:

Specifications are subject to change without notice.
Weight and dimensions are approximate.

**Panasonic Company, Division of
Matsushita Electric Corporation of America**
One Panasonic Way
Secaucus, New Jersey 07094

**Panasonic Sales Company, Division of
Matsushita Electric of Puerto Rico, Inc.**
San Gabriel Industrial Park
65th Infantry Ave. Km. 9.5
Carolina, P.R. 00630

**Panasonic Company (West) of America, Division of
Matsushita Electric Corporation of America**
6550 Katella Ave.
Cypress, CA 90630

Matsushita Electric of Canada Limited
5770 Ambler Drive,
Mississauga, Ontario L4W 2T3